

Installation and Care Instructions

Duette® Honeycomb Shades

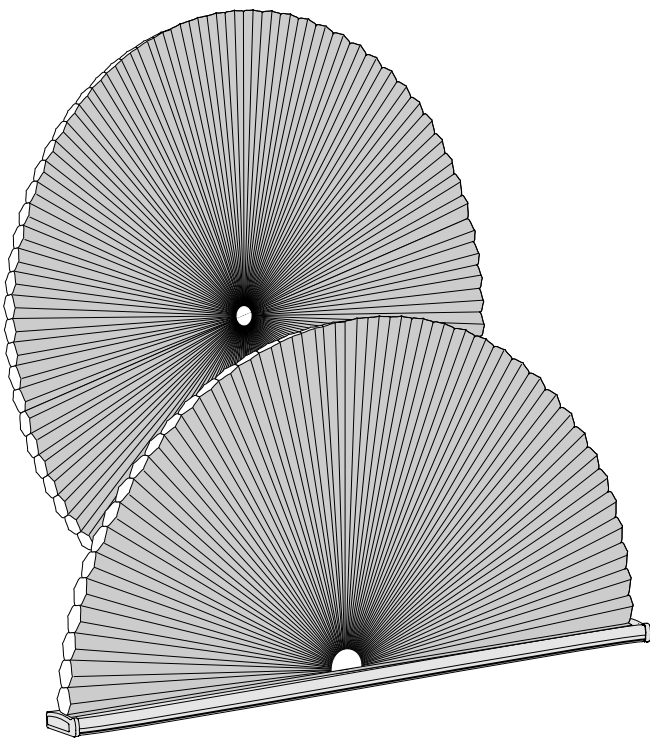

Arches, Circles,
and Quarter Circles

HunterDouglas



THANK YOU for purchasing a Hunter Douglas product. Your new shade has been custom built for you from the highest quality materials. Once in your window, it will provide you with a lifetime of beauty and trouble-free use.

Getting Started

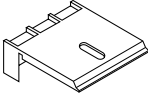
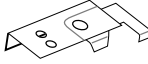
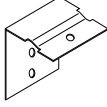

- Remove the shade from the package. Keep the packaging until the shade operates to your satisfaction.
- Check the chart to make sure you have the necessary parts. The components you receive for your shade were specified at the time the shade was ordered, based upon your particular installation needs.

Installation Components

Mounting Brackets

	Standard Installation Bracket	For Stand-Alone Arches Only (Inside And Outside Mount)
	Swivel Bracket	For Stand-Alone Arches With Shallow Window Casements (Inside Mount Only)
	Specialty End Mount Bracket	For Stand-Alone Arches, Arches Over Standard Shades, And Quarter Circles (Inside Mount Only)
	Specialty Wall Mount Bracket	For Stand-Alone Arches, Arches Over Standard Shades, And Quarter Circles (Outside Mount Only)

Other Installation Components

	Arch Support Hook	For Lighter-Weight Fabrics To Support The Fabric And Minimize Light Gap (Inside Mount Only)
	Arch Support Clip	For Mounting Circles And To Help Support Fabric On Quarter Circles And Arches (Inside Mount Only)
	End Caps	For Rail Ends

Tools needed for installing your shade:

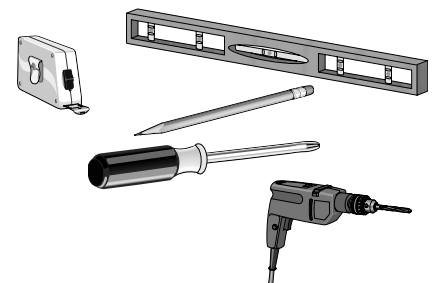

- Level
- Measuring tape
- Pencil
- Phillips screwdriver
- Power drill and drill bits



For assistance, call the Hunter Douglas
Customer Information Center
at 1-888-501-8364

Visit our Web site at hunterdouglas.com

In addition, you will need fasteners designed to work with your specific mounting surface:

Mounting Surface	Fastener
Wood	No. 6 Hex Head Screws (Provided) 
Drywall, Plaster	Wall Anchors, Expansion Bolts (Not Provided) 
Metal	Sheet Metal Screws (Not Provided) 

1 Arches

1. Install the Fabric to the Rail

The shade has a rail that contains a filler strip inserted into the bottom cell of the fabric stack. The fabric stack has one straight side and one trimmed side.

- The curved side of the rail is the front of the shade.
- Remove the left end cap from the rail.
- Slide the fabric stack down to the left side of the rail.

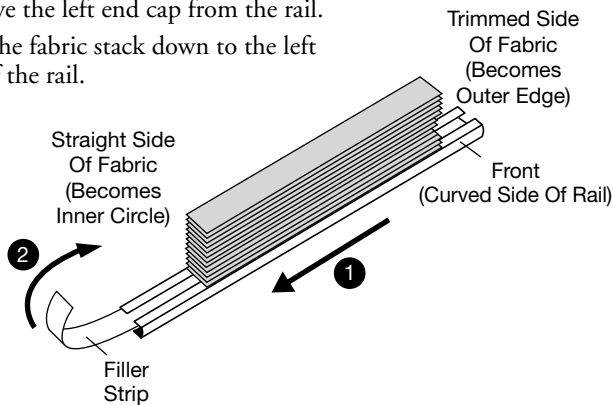

- For arches sharing the headrail with a cordlock shade: Remove the headrail end cap and slide the bottom cell of the fabric onto the smaller grooves on the top of the headrail.
- For arches that are not perfectly circular: Note the right and left sides that are marked on the fabric stack.
- Gently bend the filler strip and insert it into the top cell of the stack.
- Fan out the fabric and slide the top cell onto the fabric grooves of the rail. Center the arch.

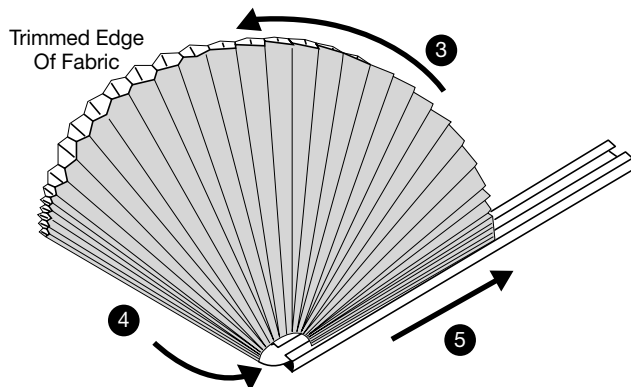

- Attach the end caps to the rail.

2. Mount the Installation Brackets

- The number of brackets you will use depends on your shade width.
- Verify which type of installation bracket you have for your shade.
- Follow the instructions for your particular brackets and mounting.

Mounting Brackets (Excluding Specialty End Mount Brackets)

Shade Width	Number Of Brackets
Up To 31"	2
31 ¹ / ₈ " To 60"	3
60 ¹ / ₈ " To 84"	4

Standard Installation Brackets (Stand-Alone Installation)

Inside Mounts: See chart below.

Standard Bracket Placement: Inside Mount

Bracket Type	Minimum	Fully Recessed
3/8" Standard	1"	1 ⁵ / ₈ "
3/4" Standard	1"	2 ³ / ₄ "

Outside Mounts: Requires a flat vertical surface at least ⁵/₈" high for ³/₈" rail or at least ⁷/₈" high for ³/₄" rail.

- Position two brackets on the mounting surface so that their centerlines are 3" in from each end of the shade.
- If more than two brackets are required, space them evenly between the two end brackets.
- Push the rail into the brackets. Make sure fabric is not caught between the tab and the rail.
- Tighten the tab screw on each bracket. Do not overtighten. If necessary, gently move the fabric forward to access the screw.

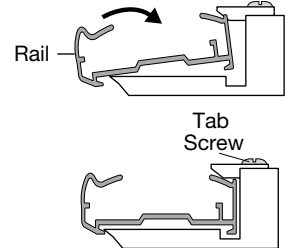

Swivel Brackets (Stand-Alone Installation Inside Mount)

See the chart below for mounting depths.

Swivel Bracket Placement: Inside Mount

Bracket Type	Minimum	Fully Recessed
3/8" Swivel	1/2"	1 ¹ / ₄ "
3/4" Swivel	1/2"	2"

- Position two swivel brackets so their screw holes are 3" in from the ends of the shade. If additional brackets are required, center them between the two end brackets.
- Use one screw to attach each bracket to the mounting surface. For ³/₄" rail, use the front hole if a mounting depth of 1" or more is available. Use the rear hole only if the mounting depth is between ¹/₂" and 1".

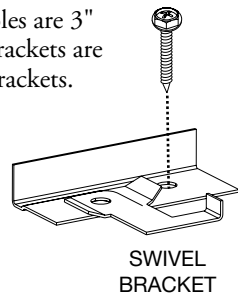

CAUTION: Do not attach a screw through the swivel eyelet on the bracket.

- Position the locking tabs on each bracket in the open position.
- With the front side of the fabric facing you, lift the shade into position so the rail is against the back of the brackets.
- Rotate the moveable tabs against the headrail to lock into place. Make sure the shade is tightly secured.

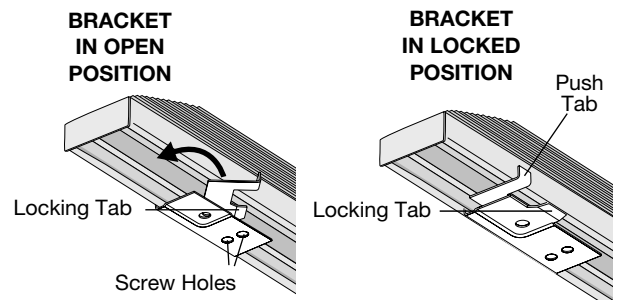

3. Install the Arch Support Clips (If Applicable)

Inside Mounts:

- Attach clips to the mounting surface through the hole in the top.

Outside Mounts:

- Attach clips to the mounting surface through the slot at the back of the clip.
- Install the first clip at the top of the arch, holding the center cell of the fabric.
- If using a support cord, secure it to the screw that holds the center clip.
- If necessary, space additional clips evenly along the arch so the clips are spaced no more than 19" apart.

Arch Support Clips

Shade Width	Number Of Clips
Up To 23"	1
23 ¹ / ₈ " To 46"	3
46 ¹ / ₈ " To 69"	5
69 ¹ / ₈ " To 84"	7

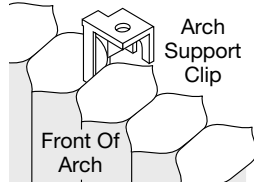

- Install the shade into the mounting brackets.
- Support the fabric and carefully use the pointed end of the hooks to puncture the fabric between the glue lines (at least 1/8" into the cell).
- Continue to support the fabric until all hooks are engaged.
- If necessary, bend or reconfigure to shape the arch to the best possible appearance.

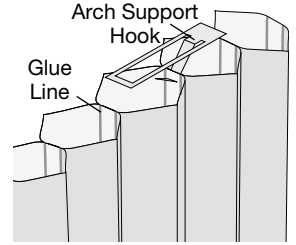

4. Space Arch Support Hooks (If Applicable)

- Verify the number of hooks needed to support your shade.

Odd number of hooks:

- Position the first hook at the top center of the window opening.
- Position the next two hooks at 45°. Space the remaining hooks evenly. Do not position the hooks lower than 45° from the bottom of the arch.

Even number of hooks:

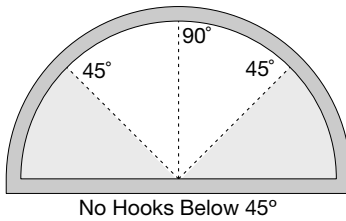

- Position the first two hooks at 45° from the bottom of the arch.
- Space the remaining hooks evenly.
- If a support cord is used: install a separate screw above the center cell to hold the cord.

5. Install Arch Support Hooks (If Applicable)

NOTE: To help find the correct depth, place the shade into the mounting brackets and mark on the sill where the exact center of a fabric cell is located. This is where the point of the hook should be located. Remove the shade before proceeding.

- Attach each arch support hook with the Phillips screw provided. Be sure to mount the hooks at a consistent depth within the sill.

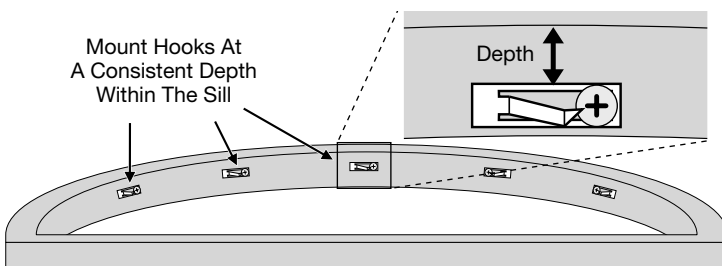

Angled View Of Arched Window Sill

2 Circles

Thread the Fabric

- Cut two pieces of the cord two feet longer than the diameter of the finished circle.
- Weight the ends with a small washer to make it easier to thread the cord through the cells.
- Place the cylinder so it is standing on end and drop the ends of one cord through fabric cells on the opposite side of the circle. Count the cells to make sure the cells are exactly opposite.
- Thread the other cord through opposite-side cells centered between the first two cells.
- Pull equal lengths of cord from the cells at the bottom of the cylinder.

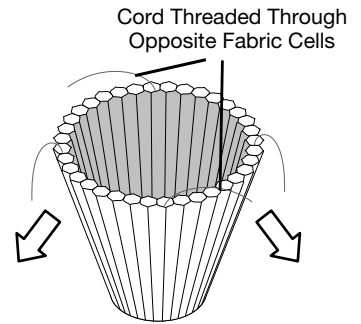

Form the Circle

- Stand the cylinder up with the loose cords at the top. The top becomes the outside curve of the circle.
- Flatten the cylinder into the circle by gently pushing down and out on the top.

Mount the Shade

- Minimum depth for inside mount is 1¹/₈" for 3/8" pleat and 1⁷/₈" deep for 3/4" pleat, double honeycomb, and triple honeycomb.
- Minimum vertical height for outside mount is 5/8" around the window opening.
- Attach four arch support clips: one each at the top, the bottom, the left side, and the right side of the shade.
- Use a ruler and a level to place the clips at the widest vertical and horizontal points of the circle.
- For inside flush mounts: Position the arch supports so the clip fingers are 3/4" inside the window casement.
- For outside mounts: Position the outer edge of the clips where you want the outer edge of the circle. Do not yet tighten the screws.
- Place the shade in the window opening with the top and bottom cords vertical and the left and right cords horizontal.
- Wrap the left end of the horizontal cord around the screw holding the left arch support clip.
- Tighten the screw on the left arch support clip.
- Pull the cord taut and wrap the right end of the cord around the right arch support clip. Tighten the screw.

- Trim excess horizontal cord.
- Repeat the process for the vertical cord with the top and bottom arch support clips.
- If the arch support clips are more than 18" apart, space additional clips evenly between them.

3 Quarter Circles

- Fan out the fabric and connect the two rails using a specialty end mount bracket (for inside mounts) or a specialty wall mount bracket (for outside mounts).
- Fit the long side of the bracket into the small grooves on the horizontal rail.
- Fit the short side of the bracket into the small grooves on the vertical rail.
- Use standard installation brackets or swivel brackets to hold the vertical rail in position. See the Arches section for bracket spacing and installation.
- Space the brackets for each rail the same as for an arch.
- Use arch support clips if the arch curve is longer than 18".

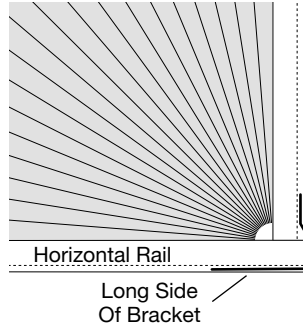

Deep Cleaning

- Immerse the shade in a basin or bathtub filled with a mild detergent.
- Rinse with clean water.
- Fully raise the shade and tilt to eliminate excess water.
- Reinstall the damp shade, lower it, and let it dry completely.

CAUTION: Do not immerse any opaque, Opalessence, Royale, or Commercial fabrics.

Ultrasonic Cleaning

Some honeycomb fabrics can be ultrasonically cleaned by a professional.

- Specify that a mild detergent solution be used.
- Never immerse the headrail in the solution.
- Dry the shade completely in the lowered position.

CAUTION: Do not ultrasonically clean Commercial, Royale, Opalessence, or opaque fabrics.

Injection/Extraction

Honeycomb shades can be professionally cleaned using the injection/extraction method.

- A dry method of injection/extraction is required for Commercial, Opalessence, Panache™, and opaque fabrics.
- If using injection/extraction for Batiste fabrics, specify that no chemicals are used (water only).

For more comprehensive cleaning instructions, call the Hunter Douglas Customer Information Center:

1-888-501-8364

4 Optional Disc Arch Cover

The optional disc arch cover can be used to cover the center holes of arch shades.

- For Arches and Quarter Circles: Remove the adhesive backing from the cover and affix it to the arch rail.
- For Circles: Affix the cover to a small pad attached by rear hooks to the circle's center cords.

5 Care And Cleaning

Honeycomb shades are made of an anti-static, dust-resistant fabric which repels dirt and dust. For most honeycomb fabrics, the following options are available if your shade needs cleaning.

Dusting

Regular light dusting with a feather duster is all the cleaning that is needed in most circumstances.

Vacuuming

Use a hand-held vacuum with low suction for more thorough dust removal.



Spot-Cleaning

- Prepare a solution of warm water and a mild detergent.
- Dampen a clean cloth in the solution and wring it out.
- Dab the spot with the dampened cloth until it is gone. **Do not rub the fabric.**
- Allow the shade to dry in the completely lowered position.

CAUTION: Do not spot-clean Batiste, Opalessence™, or Royale fabrics.



HunterDouglas

LIGHT CAN CHANGE EVERYTHING™

hunterdouglas.com

© 1985, 2006 Hunter Douglas Inc. ® Registered trademark of Hunter Douglas Inc.
™ Trademark of Hunter Douglas Inc. Patented in the U.S. and foreign countries.
Other U.S. and foreign patents pending.



PCN 5109167000

Rev. 3/06